

# MOVISI<sup>®</sup>

MODULAR LIGHTWEIGHT FURNITURE

MAKE IT YOUR SPACE



**4 THE SKY'S THE LIMIT**

**5 ONLY THE BEST**



**6 BUILD MODULAR SHELVING**



**24 U-CUBE SYSTEM**



**38 LINK PARTITION**



**56 SKYROOM OFFICE**



**64 SKYROOM MOSKITO**



**70 DREAM WINDOW SEAT**



**80 Q-COUCH**



**84 HUSH ACOUSTIC PANELS**



**92 TEARS OFF WALLPAPER**

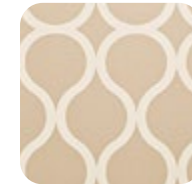

**96 ABOUT MOVISI**

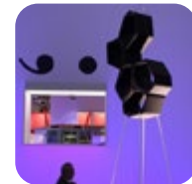

## CLIENTS



## AWARDS



## THE SKY'S THE LIMIT

Flexibility, mobility and sustainability are the pillars of MOVISI. The German company was founded in 2009 and specialises in manufacturing modular and multifunctional furniture such as partition systems, modular shelving and seating furniture for offices, home offices, modern homes, fairs, events and other environments where flexible or temporary solutions are needed.

Assembly requires no tools or special expertise, and can be carried out by just one person in a matter of minutes. Being lightweight and easy to handle Movisi furniture cuts down on transport and construction costs.

Movisi works with some of today's hottest designers to create furniture that reflects your individuality.

The collection brims with products that permit the user to 'design' their own compositions.

The light bright practicality of Movisi furniture is bound to energise you, and those around you.



Made in Germany

## QUALITY & SUSTAINABILITY FIRST

There is no substitute for quality. This is why we only use carefully selected materials that fit with our philosophy, which is to provide you with creative freedom and flexibility. Movisi wants to secure good quality as well as take on social responsibility. This is why our products are manufactured in Germany and adhere to strict ecological and socially-responsible production methods.

But quality means even more at Movisi. From research to final product, we monitor every step of our design, manufacturing and marketing processes to provide the finest quality product and most rewarding customer experience for you.

All our modular systems are made from a mono-material called ARPRO® (Expanded Polypropylene), a lightweight high performance plastic foam, which is 100% recyclable, toxic free, emission free, allergy friendly, energy absorbing, easy to clean and extremely light (95% air).

ONLY THE BEST





reddot design award  
winner

Design: Jack Godfrey Wood & Tom Ballhatchet

## BUILD MODULAR SHELVING

BUILD is a lightweight modular shelving system based on a single geometric unit. The versatile blocks can be stacked up to suit a wide range of functions – from shelves to partitions. Freestanding or mounted on the wall, BUILD adapts to your needs. The individual blocks can also double as boxes or stools.

BUILD is made from a single material (Expanded Polypropylene) which is non-toxic, allergy friendly, and 100% recyclable. BUILD is installed in minutes – no instructions or tools are needed. You can extend and reconfigure the system over time, as your requirements change.

### Modular and multifunctional

A flexible and durable system, BUILD works in the following environments:

**Retail:** shelving, product displays, wall cladding.

**Office:** shelving and partitioning, reception area, frequent workplace re-designs and co-working spaces.

**Exhibitions and fairs:** booths, product displays, storage, temporary seating.

**Special:** ideal for pop-up stores and whatever else your creative mind can think up.

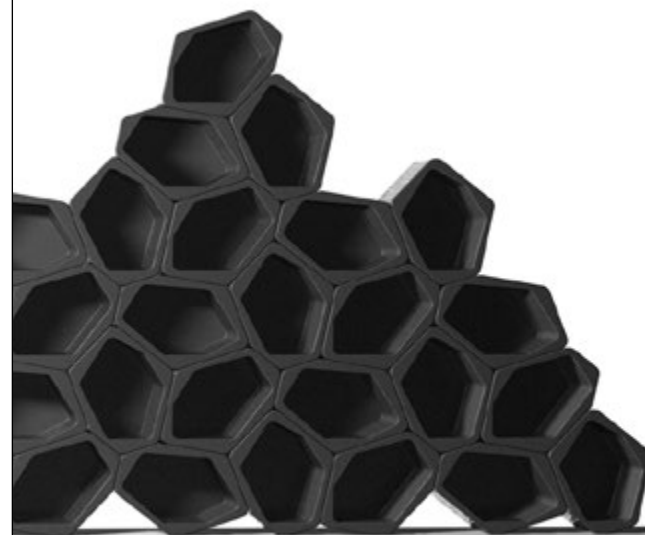

BUILD MODULAR SHELVING





black

white

available in  
black and white



BUILD MODULAR SHELVING



You can arrange the units to keep all shelves horizontal.

## SIZE, WEIGHT AND MATERIAL

### Available in 2 versions:

with back (closed) / without back (open)

### Size of 1 BUILD element:

#### External dimension in mm:

520 mm x 385 mm x D 290 mm\*

\*(D 303 mm when closed version)

**Internal dimension:** 425 mm x 315 mm x D 290 mm

**Weight:** 700-750 g /per element

**Material:** ARPRO® EPP (free of harmful substances and 100% recyclable)

BUILD comes with a silky smooth texture.

[See page 5 for more details](#)

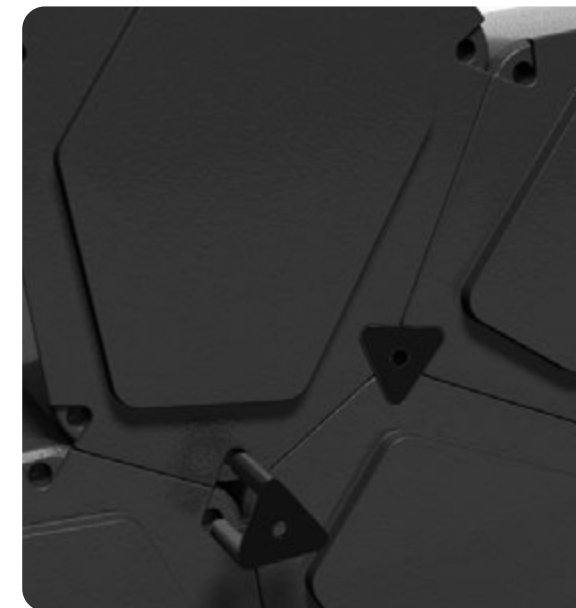
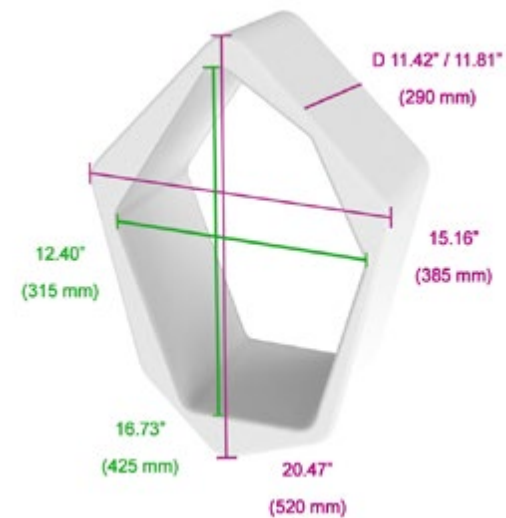





BUILD MODULAR SHELVING



Mount BUILD on the wall by using the supplied clips.



black  
white

available in black and white







BUILD MODULAR SHELVING







**BUILD MODULAR SHELVING**





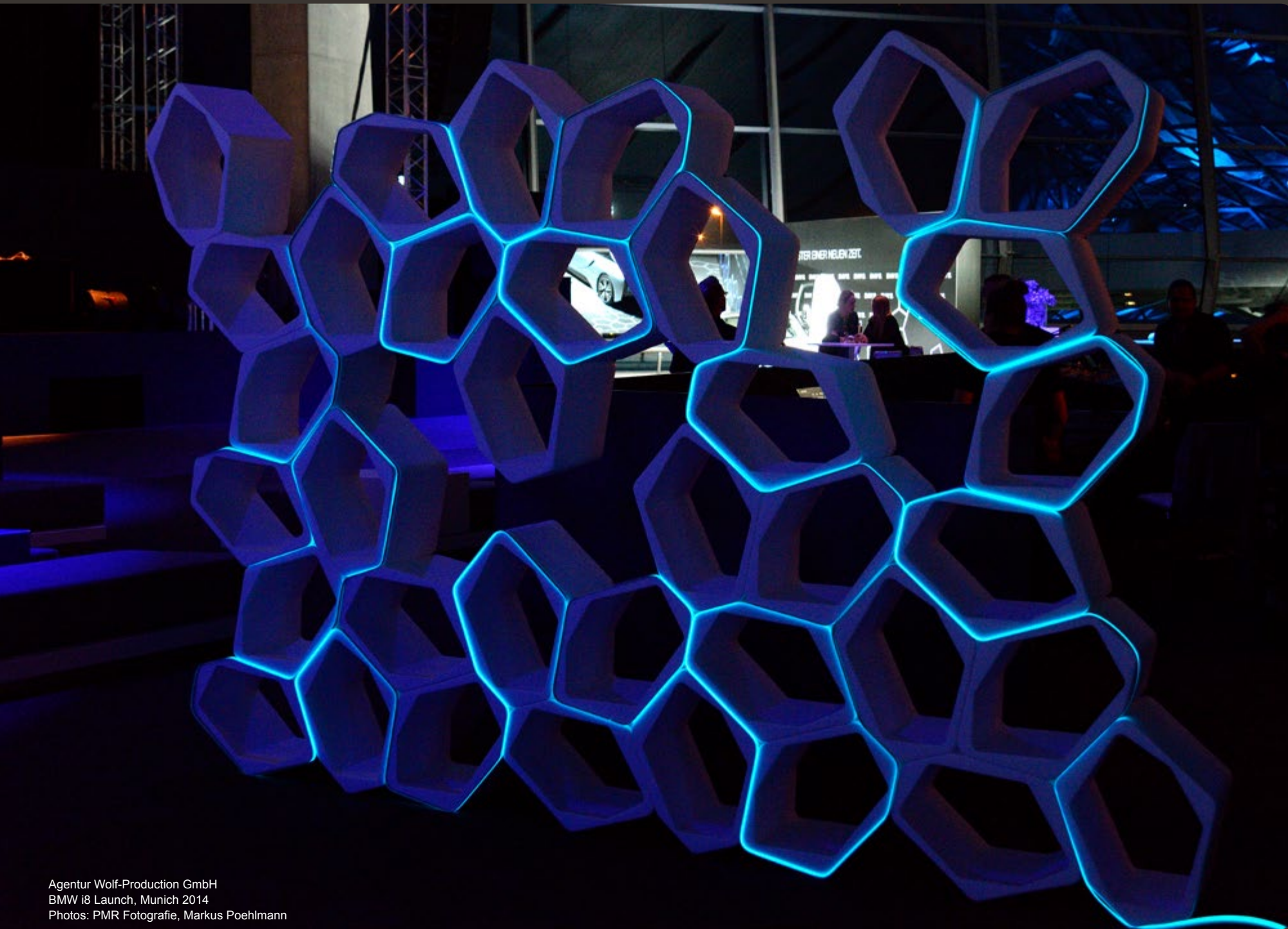

Agentur Wolf-Production GmbH  
BMW i8 Launch, Munich 2014  
Photos: PMR Fotografie, Markus Poehlmann

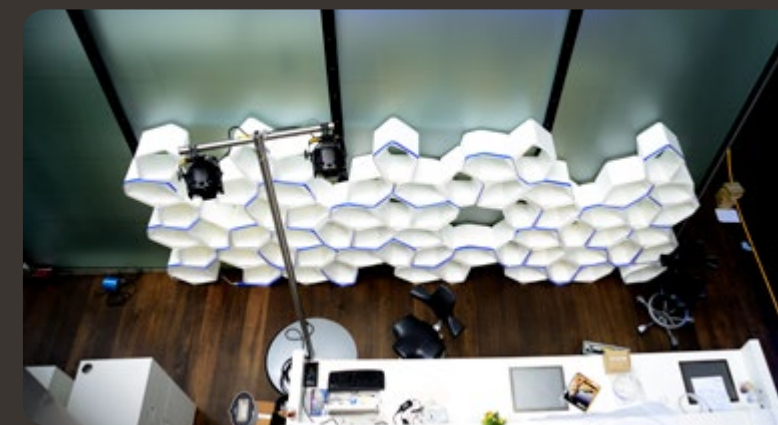
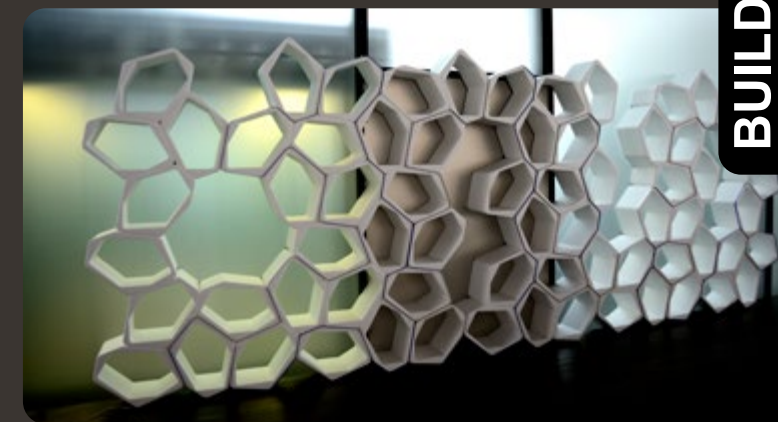
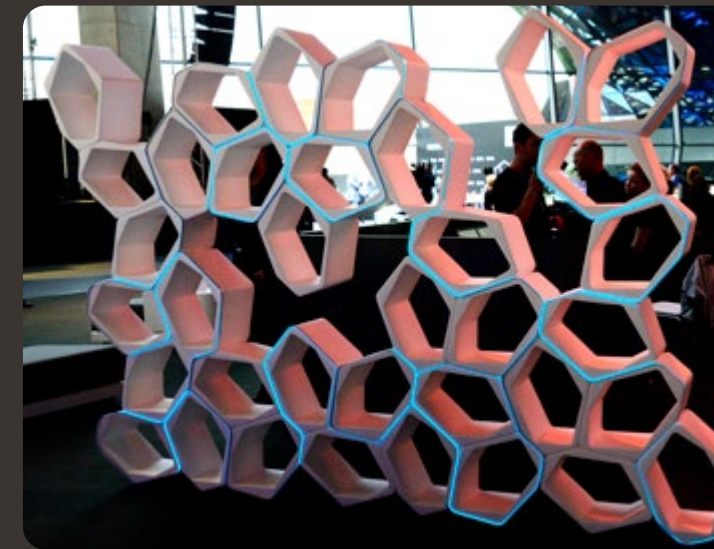

**BUILD MODULAR SHELVING**

Illumination available in various colours and designs. Individual light concepts and effects available on request.



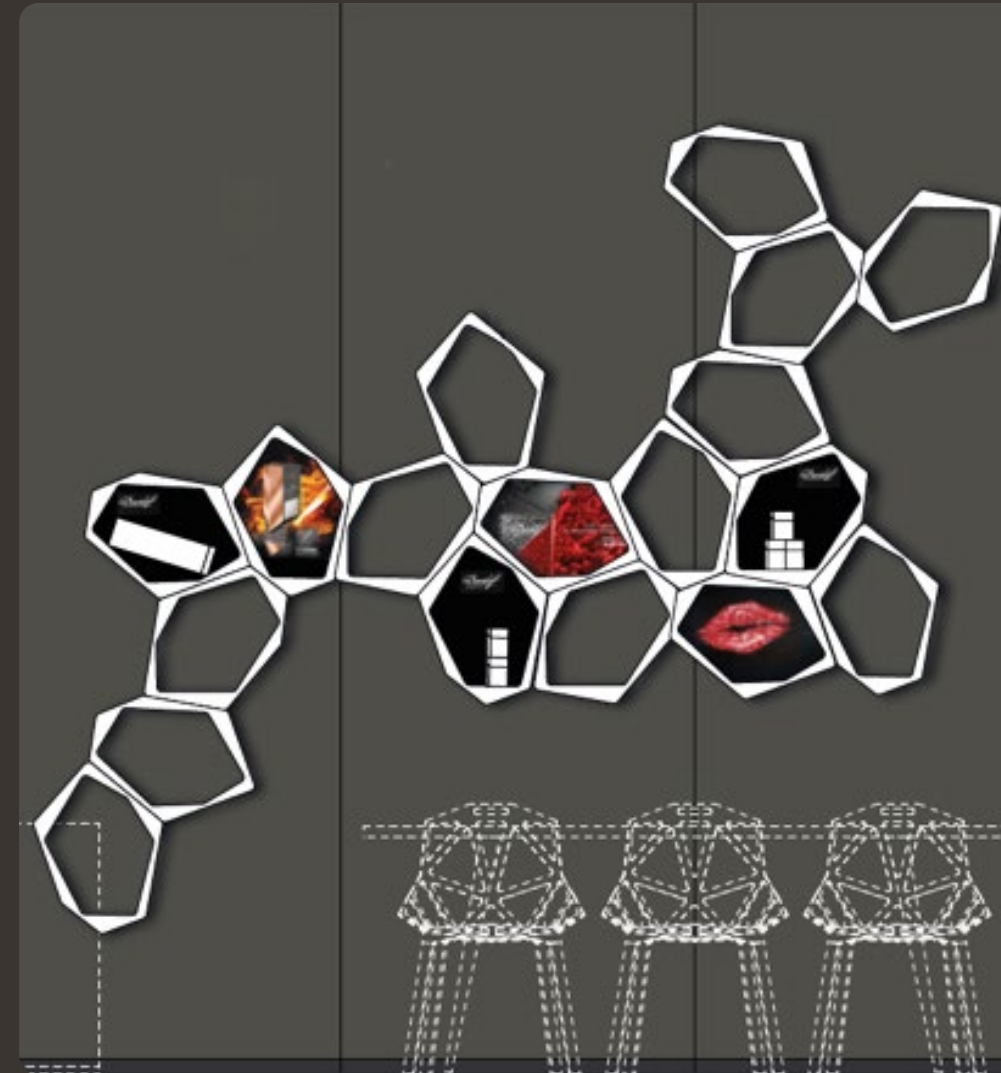
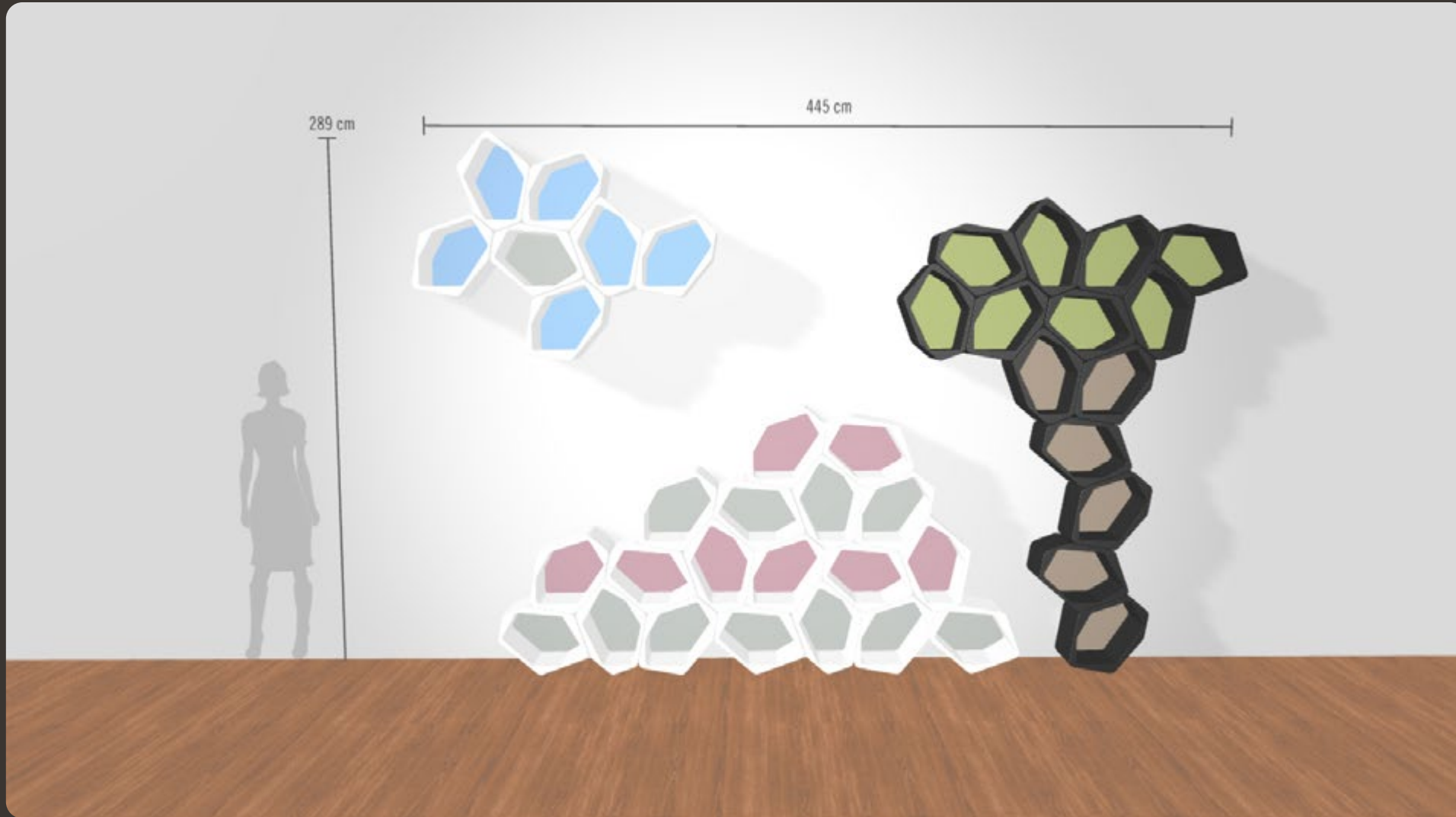

Design your custom shelving with our drag and drop online configurator.  
[Click here to get creative](#)

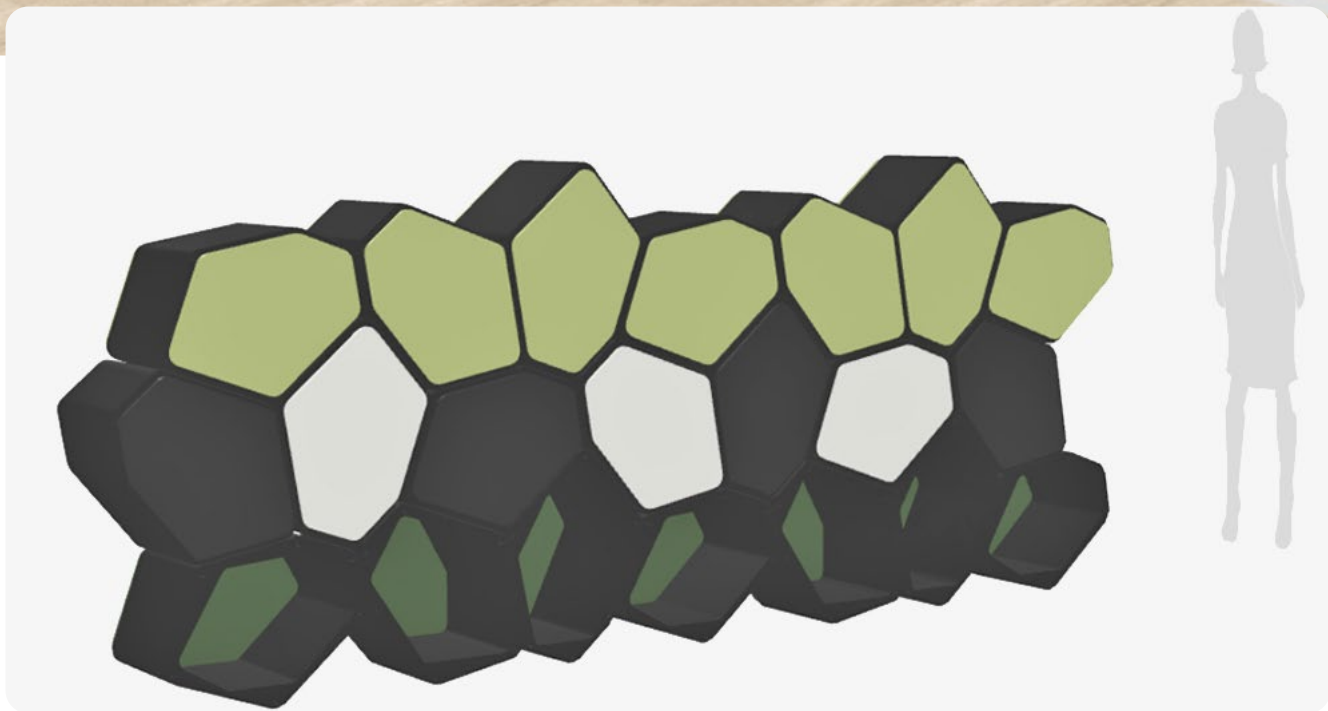

**ACCESSORIES**

Add colored acoustic inlay panels, front and backside lids/doors to customize your BUILD shelf and improve acoustics. Available in 12 colours (see page 88).

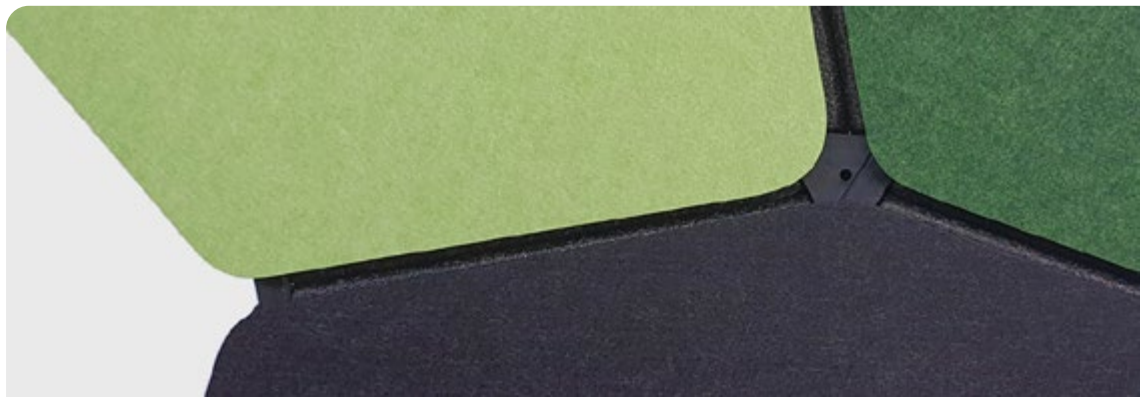





Design: Marine Peyre in collaboration with Trickform

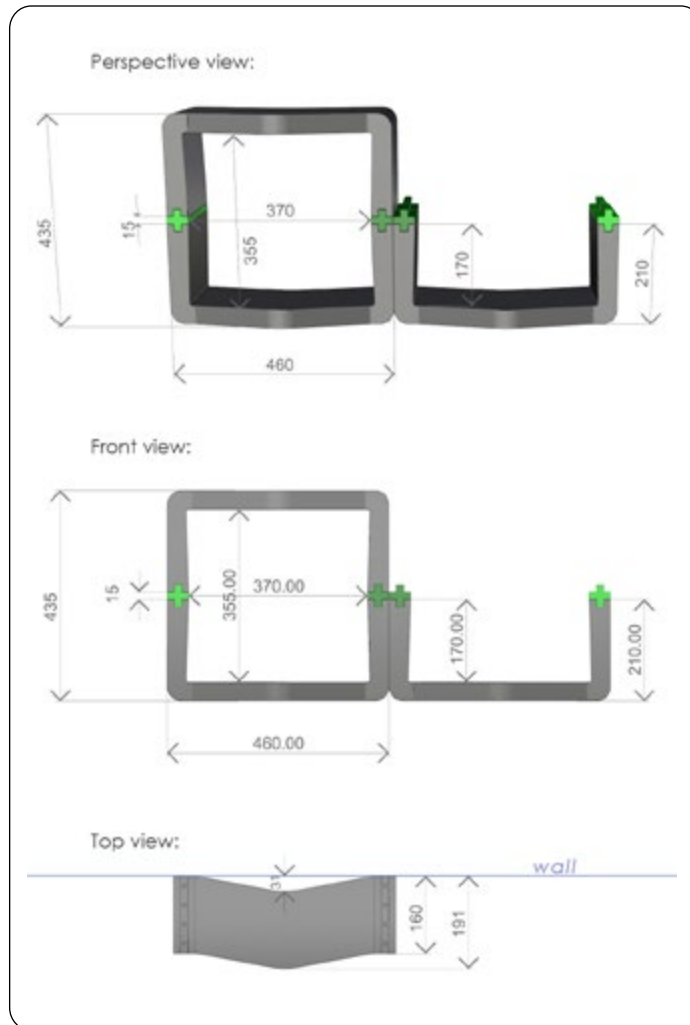

## U-CUBE SYSTEM

U-CUBE is a modular, multifunctional furniture system which builds up on a main module with modular connectors. It allows the users endless configurations and the possibility to change the style and the function of their interior setting according to their needs and wishes.

From shelving, to room divider, to seating — U-CUBE offers architects, interior designers, event planners and design lovers a single product which is adaptable to any interior environment.

Quick and easy to install and rearranged in minutes. No tools or expertise needed.

Size: see drawing.

**Weight:** ~ 0.4 kg /per module

**Material:** ARPRO® EPP (free of harmful substances and 100% recyclable)

[See page 5 for more details](#)

black

white

available in  
black and white



U-CUBE SYSTEM







U-CUBE SYSTEM





U-CUBE SYSTEM



U-CUBE SYSTEM









U-CUBE SYSTEM







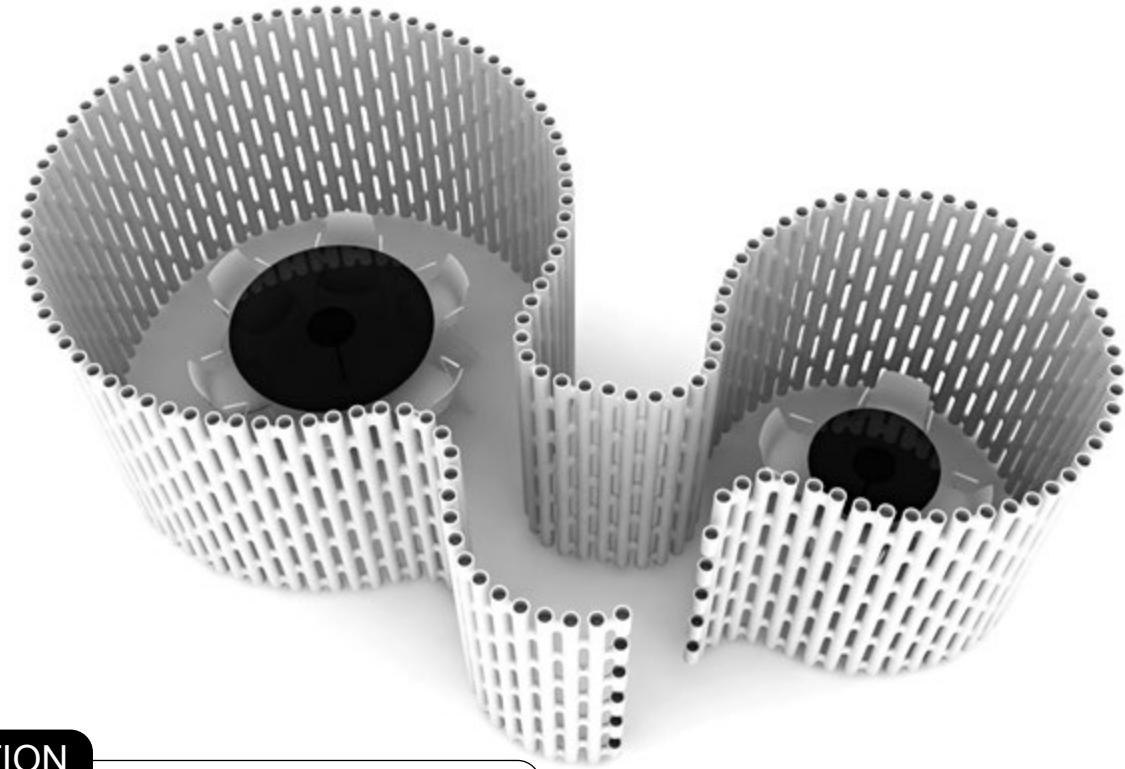

## LINK PARTITION

LINK is a freestanding modular partitioning system that features units that link together to create free-standing partitions and room dividers for different interior settings.

Quick to construct and quick to change; unique and diverse in its capabilities to modify its design as many times as the end user chooses. Assembly requires no tools or special expertise and can be done by just one person.

A LINK wall can also be accentuated by the use of coloured lighting or projections.

A flexible and durable system, LINK works in the following environments:

- **Office:** reception, break out, informal meeting areas.
- **Exhibitions and events:** booths, shrouding walkways, creating temporary press or cafe areas.
- **Retail:** shop displays, wall cladding, back drops.

Design: PearsonLloyd



LINK PARTITION



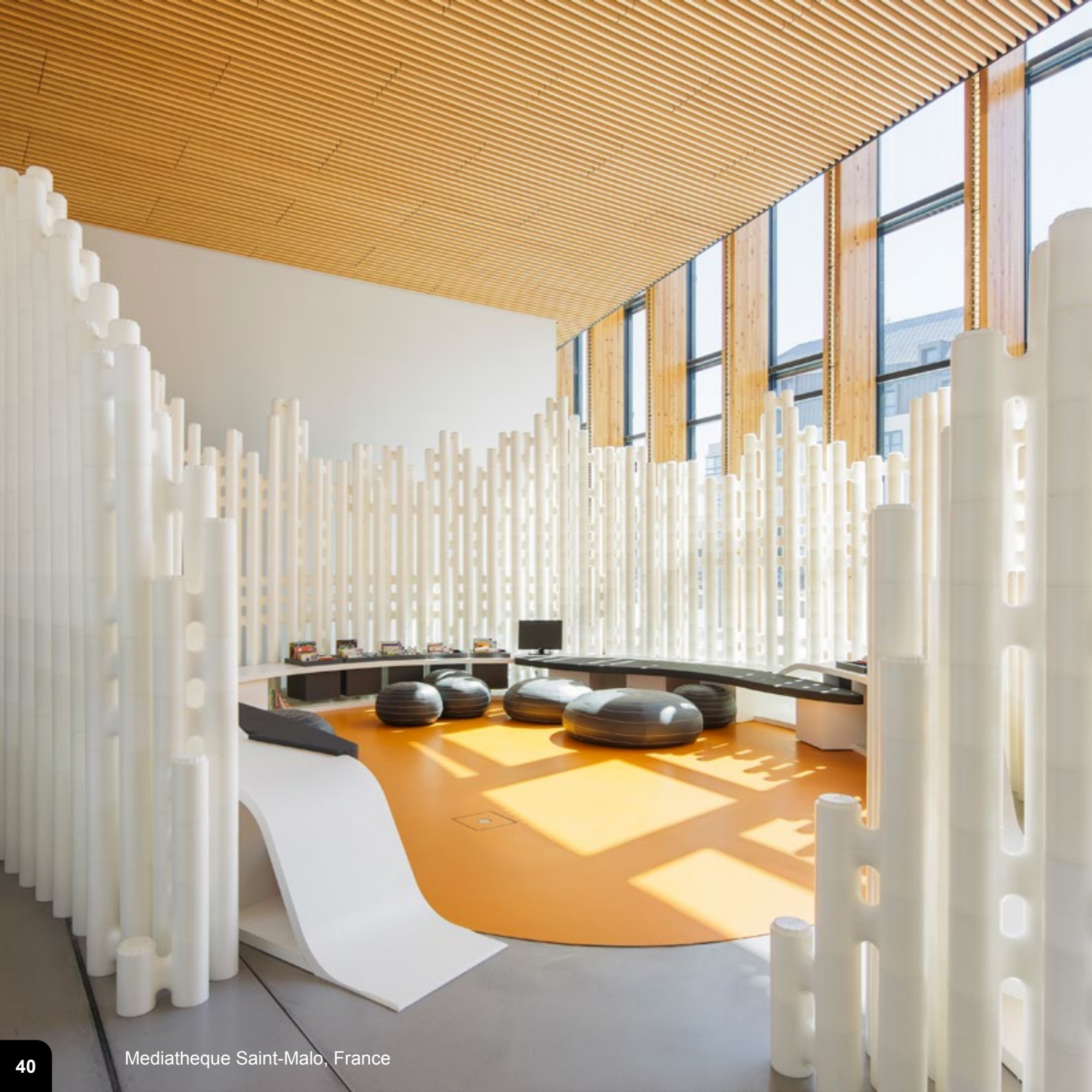

LINK PARTITION





LINK PARTITION

## SIZE, WEIGHT AND MATERIAL

15 pieces of LINK are required to build a 1m x 1m wall.

### Size of 1 LINK module:

W 288 mm x H 216 mm x D 120 mm  
(H 200 mm when linked)

**Weight:** 200 g /per piece

**Material:** ARPRO® EPP (free of harmful substances and 100% recyclable)

[See page 5 for more details](#)

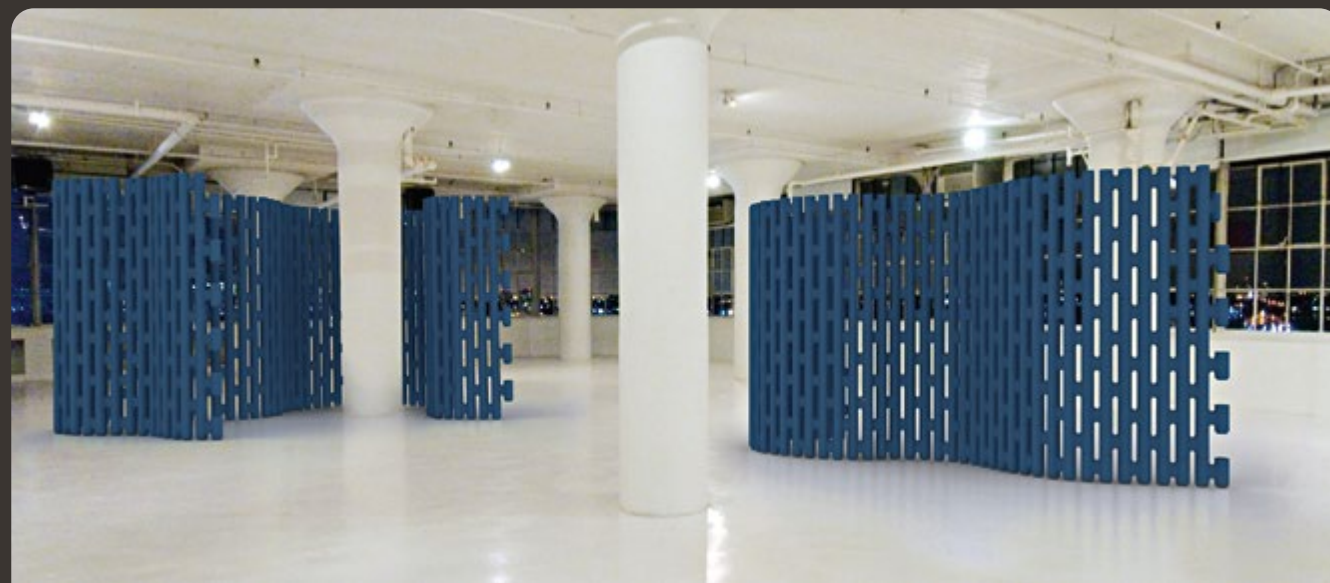

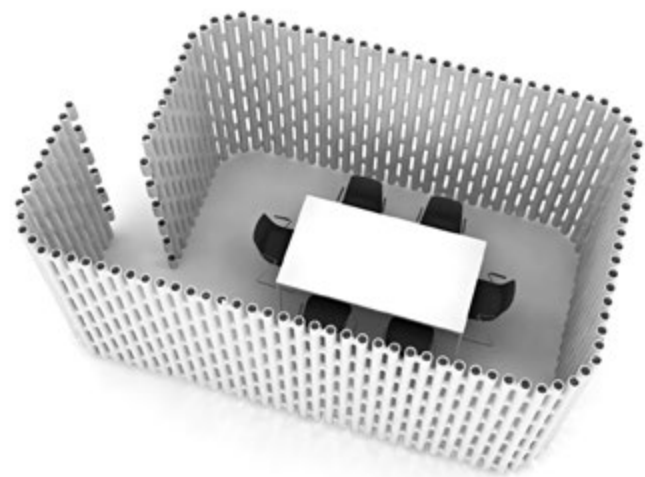

black	magenta	grey
white	red	green
	orange	blue
	yellow	

available in black and white      other colours on demand

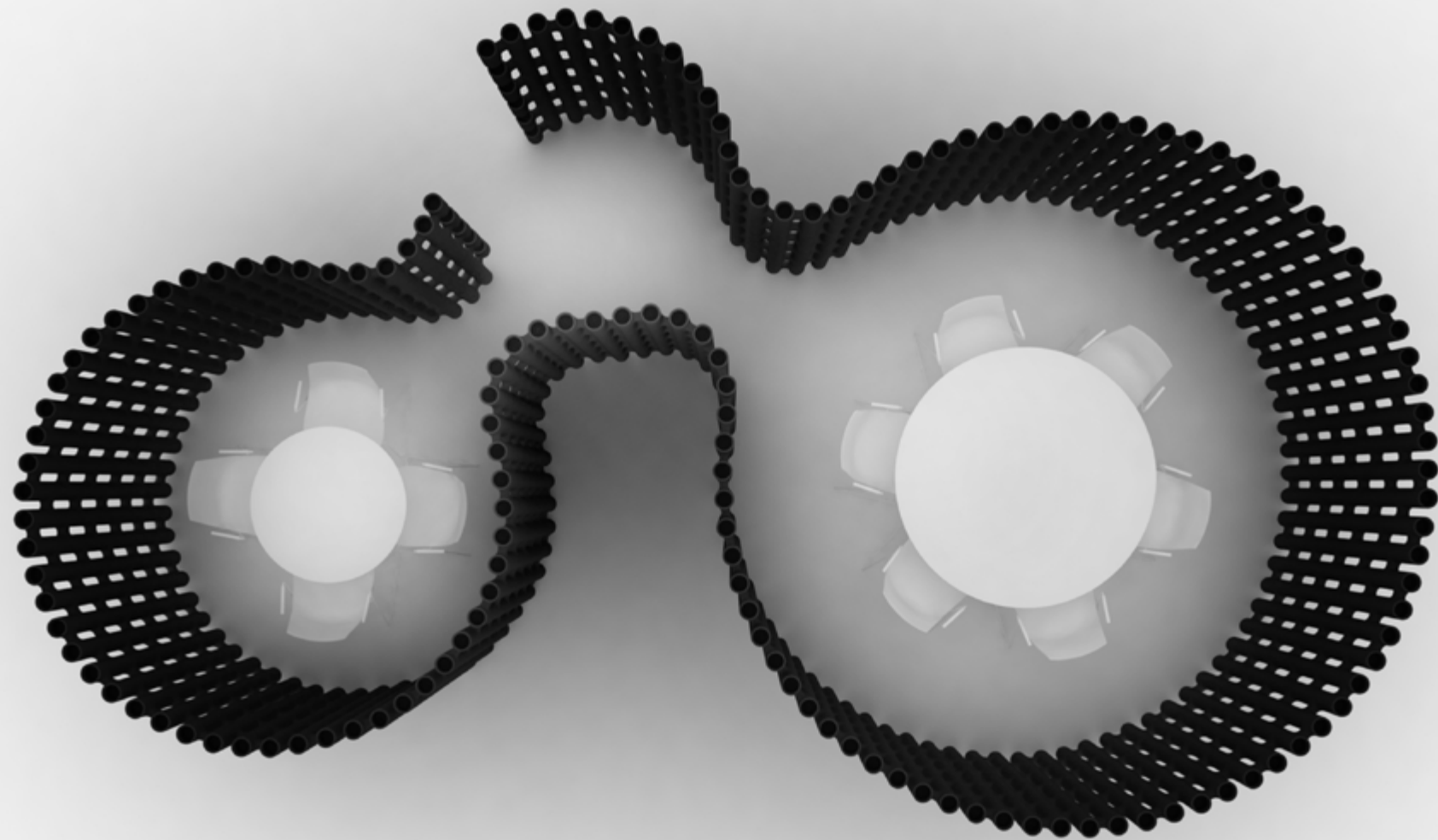

LINK PARTITION





## AT HOME

What's behind this screen? Is it a **home office space**, a dining area, a chill-out zone? Create whatever space you need wherever you need it with LINK.

This free-standing DIY room divider and partition provides a stylish, flexible, and affordable solution for increased privacy. The modular design means you can easily rearrange the configuration as your needs change or simply store them away when you're done.

LINK is a profoundly simple and innovative solution to space-making in a home or office. With this easy partitioning system in hand, you'll find yourself seeing new opportunities for creating novel, attractive spaces within your existing rooms.





LINK PARTITION





## ACCESSORIES: FILLER PLATES

Take your LINK customized space a step above and improve acoustics with filler plates in a range of carefully selected colors. These felt-like plates are made from upcycled plastic bottles (PET, minimum post-consumer content 60%) and add style with minimal weight and fuss. They also provide additional privacy and acoustic screening.

Match your corporate branding or complement your home office décor. Plate for a meeting, remove to let natural light back in. It's as simple to implement, as lightweight and environmentally conscious, as all our furnishings. The filler plates allow you to create a fully or partially closed screening. This can add an element of privacy and improve acoustic properties.

**Colours:** available in many colours. [Click here for more.](#)

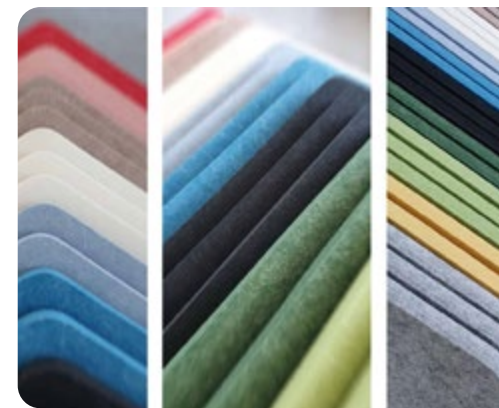













## SKYROOM OFFICE

### A flexible and mobile office pod for agile workspaces

The SKYROOM OFFICE is a moveable room-in-room system which unfolds to create a temporary space and folds away when not in use.

Ideal as working pod and meeting pod or as privacy screen for open plan offices, workstations, trade fairs, events and other environments where flexible and temporary solutions are needed.

The modular system allows various combinations which allows the user to create different room concepts and room sizes.

Each side can be folded up individually - from a completely closed pod for privacy to a completely open canopy.

While common room-in-room solutions occupy a fixed area in the room, the SKYROOM OFFICE can be moved where required.

Thus, a meeting room only takes up valuable space when really needed.

Design: Nils Bennett in collaboration with Trickform



SKYROOM OFFICE









## FLEXIBLE INTERIORS

Elegant, easy and fun to handle, SKYROOM OFFICE can be used in following interiors:

- **Offices and open plan offices:** as meeting pod or work pod: individual workstations when privacy is needed, temporary meeting rooms, presentation areas, think tanks, phone pods, retreat areas, office screening
- Coworking spaces: as meeting pod or work pod
- **Events, exhibitions and fairs:** meeting rooms, press areas, effective show presentations (e.g. unveiling of a new product), retreat areas, meeting pod, pop-up rooms for various functions
- **Shops:** foyers, dressing rooms, special collection presentations
- **Restaurants:** privacy booths, catering areas
- Other: temporary spaces, home offices, showrooms, museums





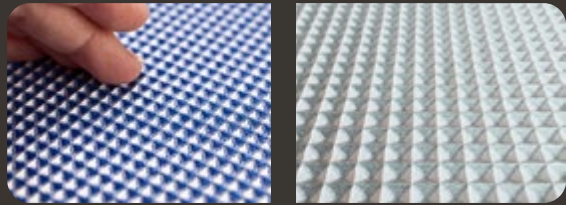
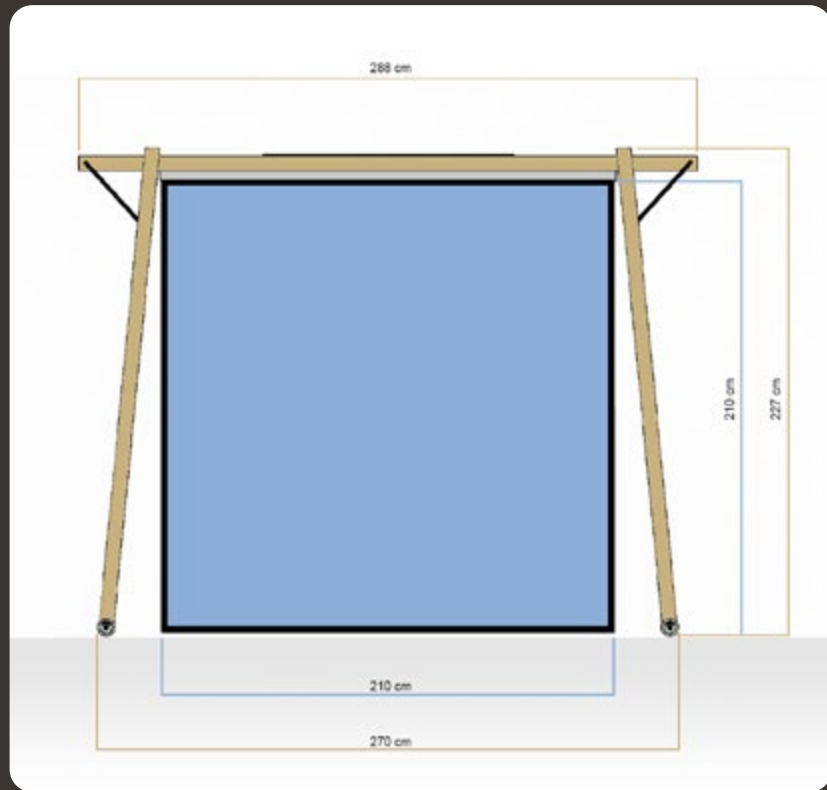

### Acoustic fabric

The four fabric walls made from three-dimensional permanently flame retardant Trevira CS fabric. Not only are the sound waves absorbed, they are also broken up with a positive impact on sound perception.

The Skyroom Office fabric is available in twenty different colour combinations.

The fabric is also suitable for high-resolution digital printing. From logo to landscape - everything is possible.

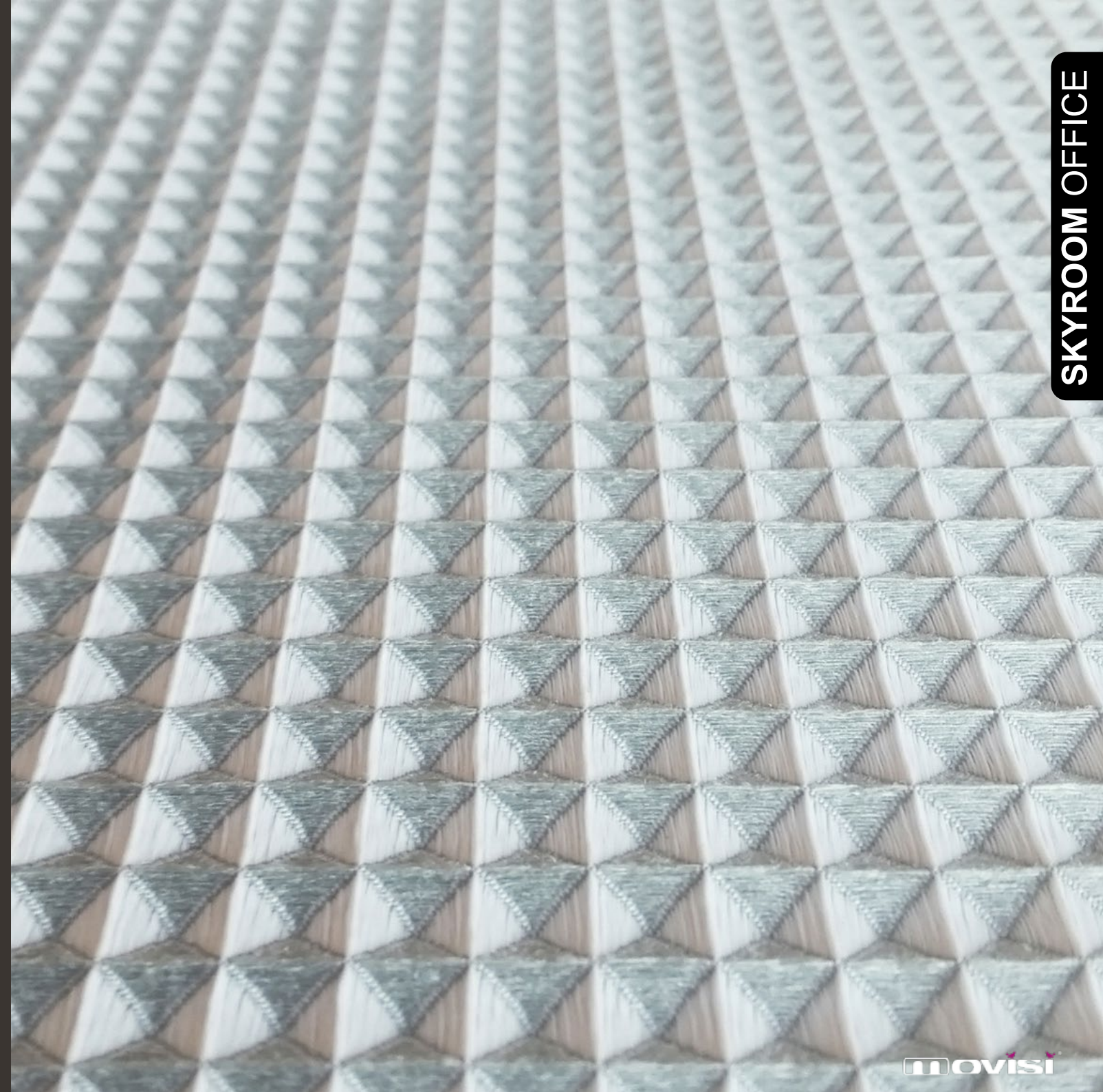

SKYROOM OFFICE





Design: Nils Bennett in collaboration with Trickform

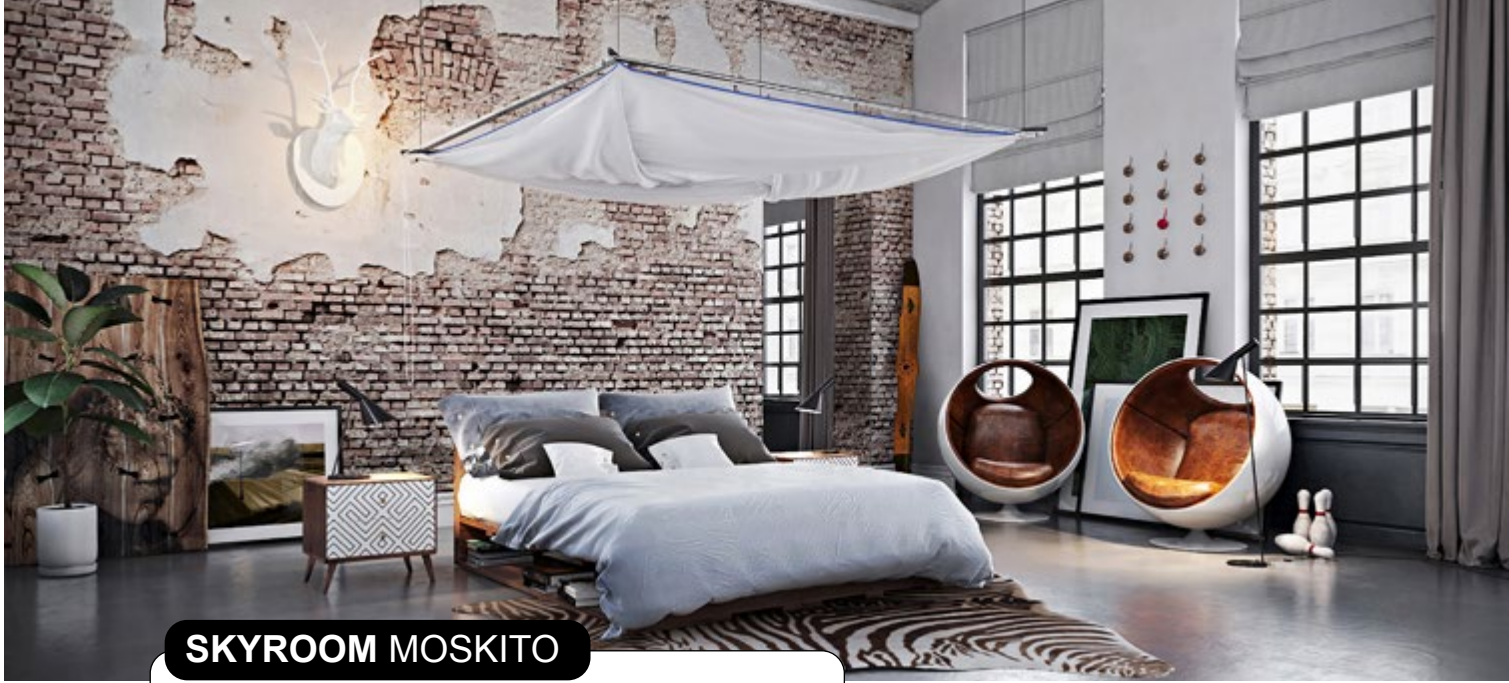

### SKYROOM MOSKITO

**A baldachin transforms into an elegant mosquito proof room:** the „SKYROOM Moskito“ is a flexible room-in-room system. It transforms any space into a comfortable insect free summer lounge with a blissful privacy. The perfect solution for undisturbed sleeping, eating, working or relaxing.

When not in use, the folded cloth creates a canopy turns the sleeping area into a pleasant place.

Elegant, easy and fun to handle, the new system can be used in residential and commercial interiors such as hotels to define and separate a space - such as the bed in an open plan loft.



SKYROOM MOSKITO





SKYROOM MOSKITO





- white
- anthracite
- stainless steel  
(suitable for outdoor use)



## OPENS WITH A MAGIC ROTATION

The SKYROOM unfolds with a magical, origami-like rotation to create a 3dimensional temporary space. The playful ease that lies behind this lightweight room-in-room system is not only functional but is also a real eye-catcher.

## SIZE AND SETUP

**Dimensions:**  
 Mosquito net cube:  
 L 220 x W 220 x H 220 cm  
 Metal frame:  
 L 250 x W 250 x H 2 cm  
**Weight:** approx. 12 kg  
**Mounting:** 4 point suspension from the ceiling  
 Minimum ceiling height needed: 240 cm

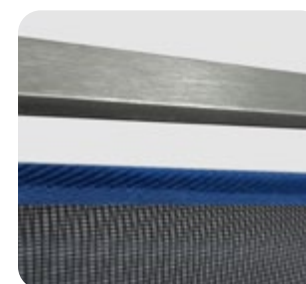
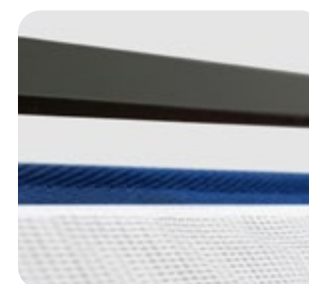
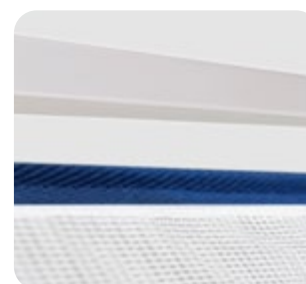





### DREAM WINDOW SEAT & DESK

A desk turns into a window seat.

Who doesn't dream of a window seat where one cozy up to the window, enjoy a nice cup of coffee and a book or simply sit and gaze out of the window?

If you have a window that you love, you can simply place the DREAM window seat beneath.

No need to make changes to your interior and therefore perfect also for rented offices and apartments, big or small.

Design: Trickfrom



DREAM WINDOW SEAT





This comfortable seat transforms into a desk in a matter of seconds.  
Simply remove the backrest and the cushions

DREAM WINDOW SEAT





Upholstery colours

mustard yellow

light grey

bamboo green

anthracite

petrol blue

other colours on demand

## TECHNICAL DETAILS

**100% handcrafted in Germany**

**Weight:** approx.25 kg

**Wood finish:** 18mm Birkoplex multilayer board with premium oak veneer.

**Steel frame:** powder coated (anthracite)

**Decorative acrylic inlay stripes,** available in various colours

**Textile:** Faux wool: 100% PES, available in various colours.

Martindale: >60.000 cycles. According to DIN EN 14465:2006

Foam: high quality foam with varying densities for maximum comfort.





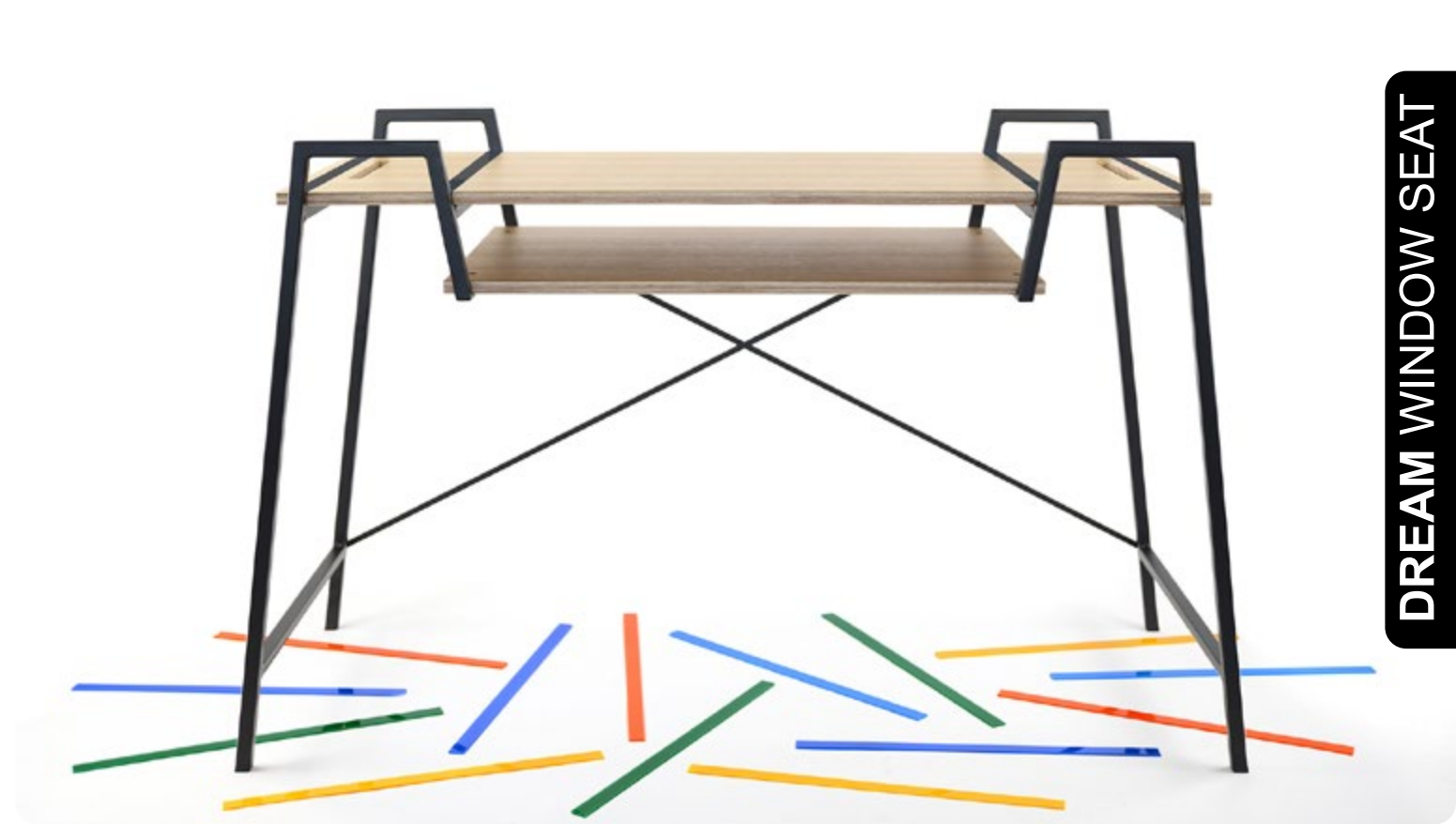
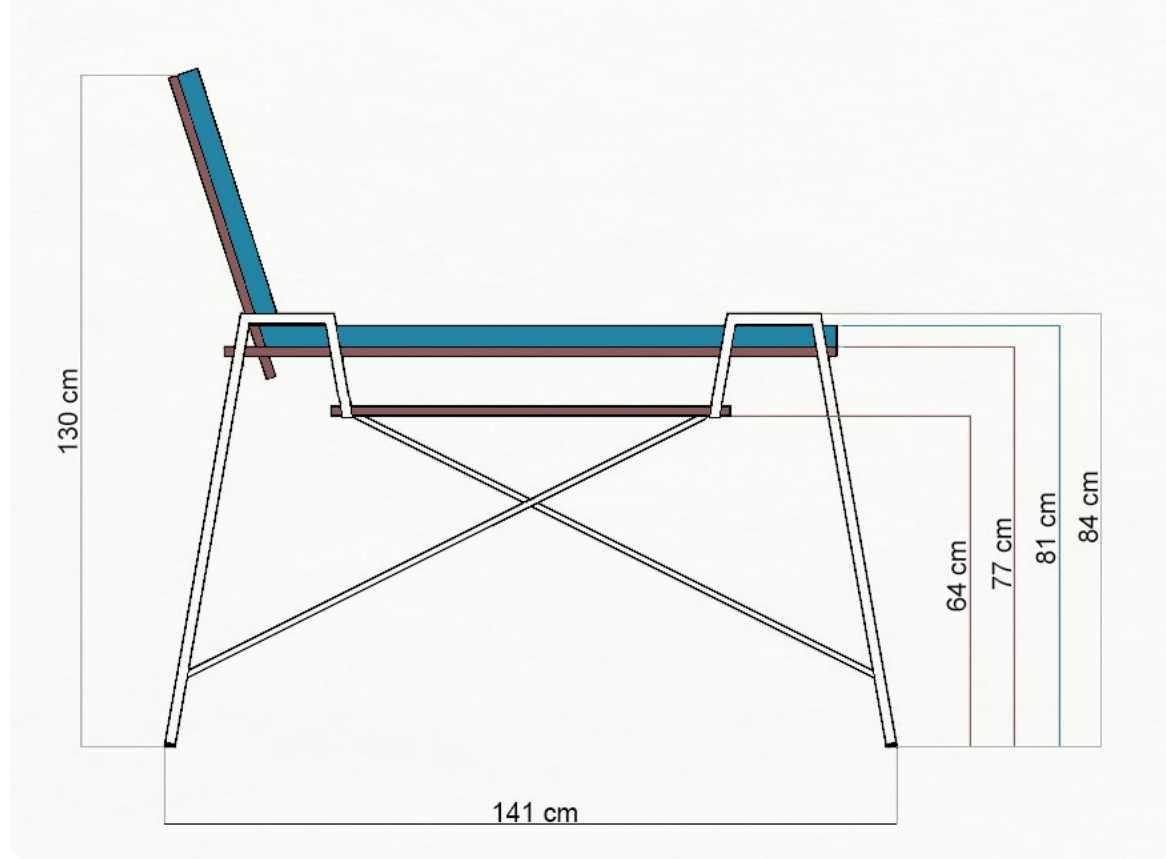

## SIZE

### When used as seat (with backrest and cushions):

L 141 cm, W 54 cm, H 130 cm (removable backrest)

Seating height: approx. 77 cm

### When used as desk (without backrest and cushions):

L 141 cm, W 54 cm, H 84 cm (top edge steel frame)

Desk/table top: L 118 cm, W 50 cm, working height table top 77 cm

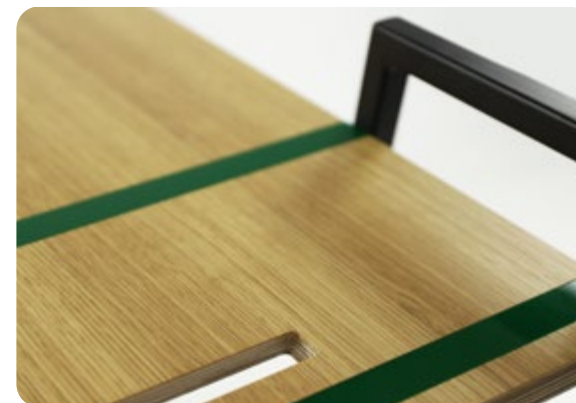





DREAM WINDOW SEAT





## Q-COUCH

This modular sofa system has some very special qualities. The first thing that stands out is its organic and light-hearted appearance. In order not to limit your creativity this couch can be „Q-ued“ in all lengths, and colours in any way you want.

Design: Frederik Van Heereveld



Q-COUCH





Q-COUCH

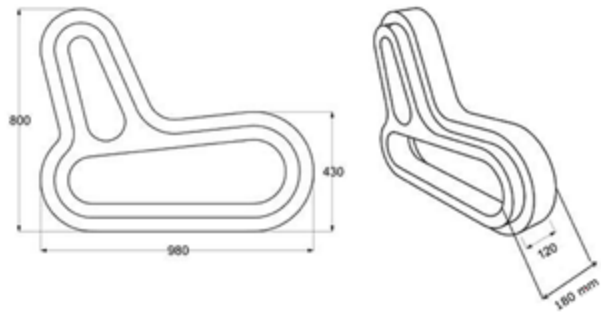

**SIZE AND WEIGHT**

**Size of 1 Q-COUCH module:**  
 L 980 mm x H 800 mm x W 120 mm  
 (W 180 mm when not connected)

**Weight:** approx. 1.5 kg /per piece

**Material:** ARPRO® EPP  
 free of harmful substances and 100% recyclable

[See page 5 for more details](#)

<b>black</b>	<b>magenta</b>	<b>grey</b>
<b>white</b>	<b>red</b>	<b>green</b>
	<b>orange</b>	<b>blue</b>
	<b>yellow</b>	

available in black and white      other colours on demand







## HUSH ACOUSTIC PANELS

MOVISI's HUSH acoustic panels are a designer solution to the common issue of workplace sound mitigation. These sustainable felt-like panels play to sight, hearing, and touch. HUSH comes with pre-installed 4 mm-thick self-adhesive magnets. This space between the wall and the panel are key for buffering sound, making HUSH wall panels more effective, more attractive, and more flexible: once installed, the honeycomb panels appear to float on their mountings, allowing light play and reducing sound pollution. The panels can be extended, exchanged and rearranged easily, without any tools.

Made from recycled PET bottles. LEED accredited and Cradle to Cradle certified. HUSH is available in 12 curated colors, developed by London trend scouts Colour Hive™.

Design: Trickform



HUSH ACOUSTIC PANELS





movisi



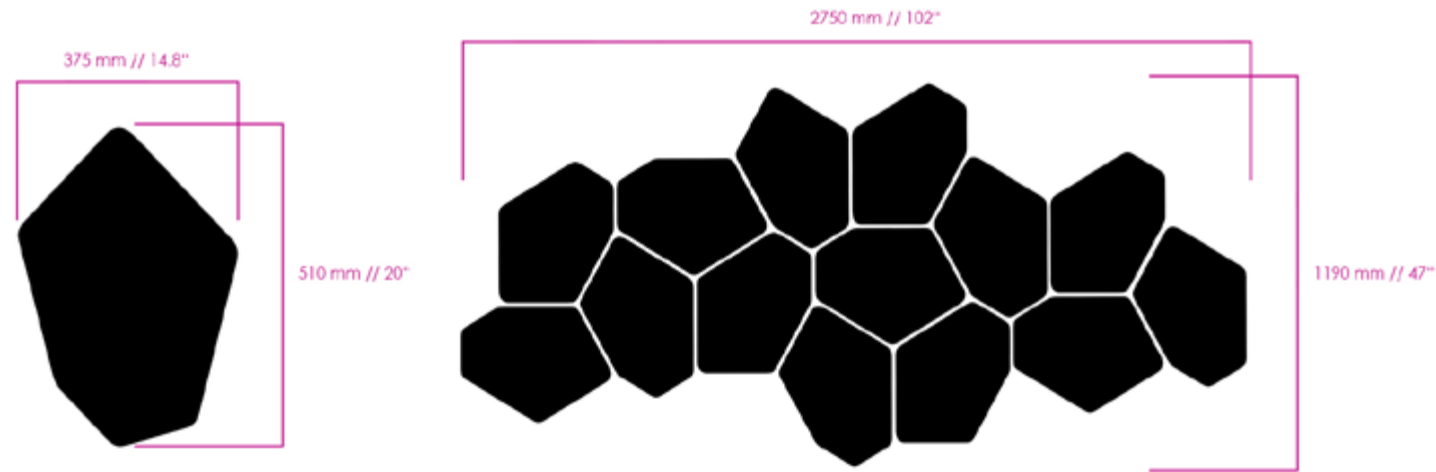

## SIZE, WEIGHT AND MATERIAL

**Size:** W 375 mm x H 510 mm x D 12 mm

**Weight:** 315 g /per panel

**Material:** Made from recycled PET bottles (minimum post-consumer content 60%). LEED accredited and Cradle to Cradle certified.



HUSH ACOUSTIC PANELS





HUSH ACOUSTIC PANELS





Design: ZNAK, Aldo Kroese, Studio Hausen

### TEARS OFF WALLPAPER

TEARS OFF is a modular wallpaper. The innovative wallpaper is created with a specially designed perforation. By tearing off pieces of the wallpaper, you can create your own unique space. The colour and texture underneath the wallpaper will become a significant element within the design. Tearing off pieces of the wallpaper is an easy and creative process.

### SIZE AND MATERIALS

**Dimensions of 1 sheet:** H 1000 mm x W 465 mm  
**Material:** Vinyl coating on a non woven backing  
**Flammability:** European Class : B-s2 -d0EN 13501-1  
**Lightfastness:** ≥ 7 international woolscale / BS1006; ISO 105-B02; DIN 54004

### Awards

Best New Product, I.D. Magazine  
 Certificate of Excellence in Materials, Material ConneXion  
 Best Product, Heimtextil Frankfurt

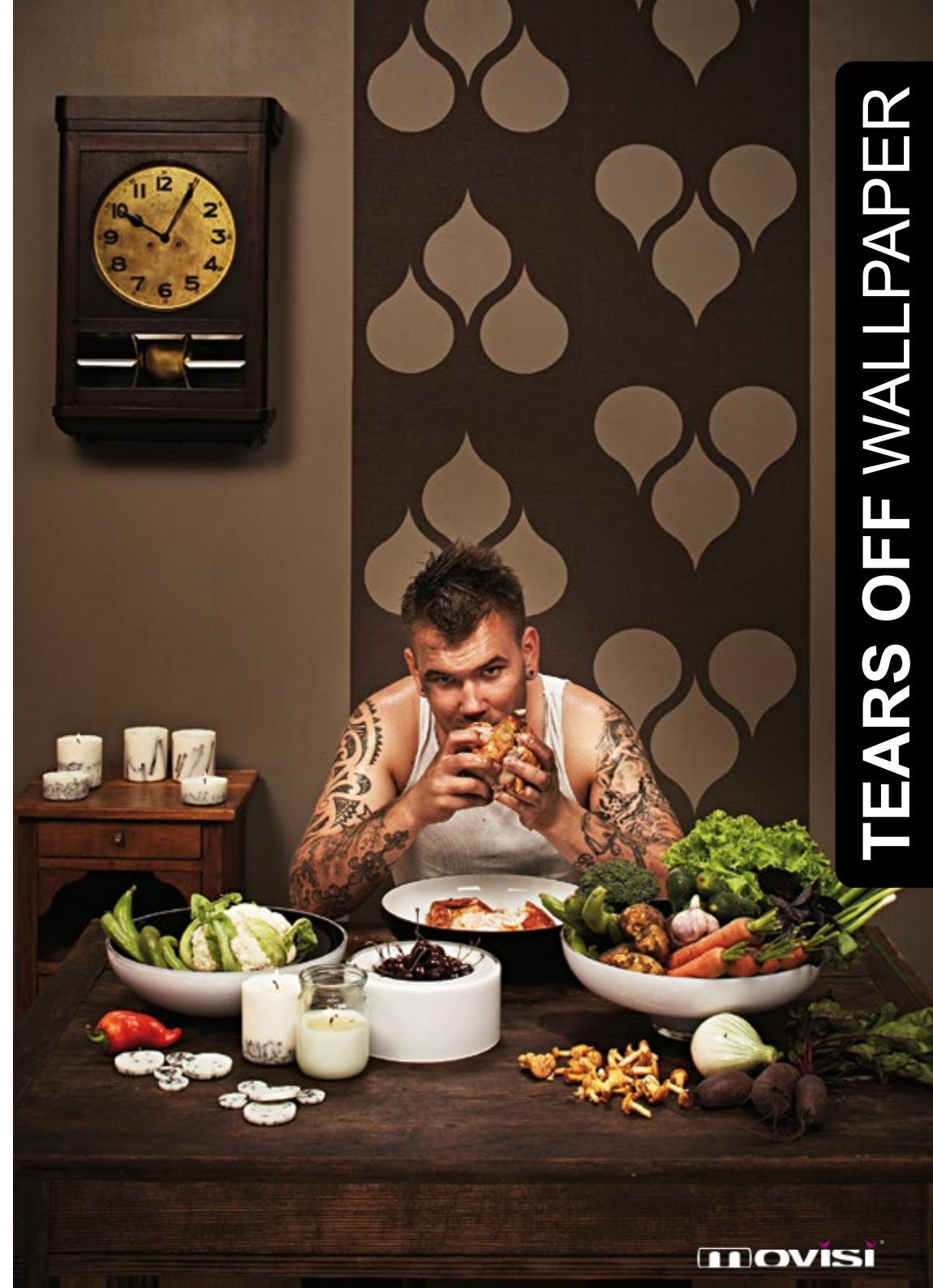

TEARS OFF WALLPAPER





TEARS OFF WALLPAPER



## SUSTAINABILITY & DESIGN PHILOSOPHY

### Sustainable furniture production

We are always working on minimizing our business operations' impact on the environment. MOVISI products adhere to strict ecological and socially responsible production methods. MOVISI furniture is 100% recyclable, entirely toxin-free and 100% made in Germany.

**Green power:** our offices and our warehouse are powered by 100% green electricity from Greenpeace. 100% free of CO2 emissions. Power/electricity is mostly generated from eco-friendly hydropower.

**Minimal packaging:** MOVISI furniture is very light in weight: this means that CO2 emissions are reduced during transport as less fuel is needed to move the goods. We avoid unnecessary packaging. Our goal is to keep waste towards zero. This is why we only use cardboard boxes for packaging our modular furniture. No additional packaging and padding material is being used.

**Lightweight transport:** our furniture is very light in weight: this means that CO2 emissions are reduced during transport as less fuel is needed to move the goods.

### Light, flexible and customisable

We think that everyone should have more choices when it comes to the character of their home decor or office environment. Our aim is to offer you endless interior design possibilities. MOVISI does not dictate a style, but rather allows you to establish your own personal style with furniture that you can customise and change as it suits you. The results can be unexpected, individual and dynamic. You are in control. The furniture changes with a whim, and with minimum effort. The results can be as surprising and evocative as your own imagination - furniture that adapts to your needs. The interchangeable components make the furniture dynamic and responsive to changing needs. These characteristics combine to make MOVISI one of the world's most unique range of furnishings available anywhere today.



Made in Germany

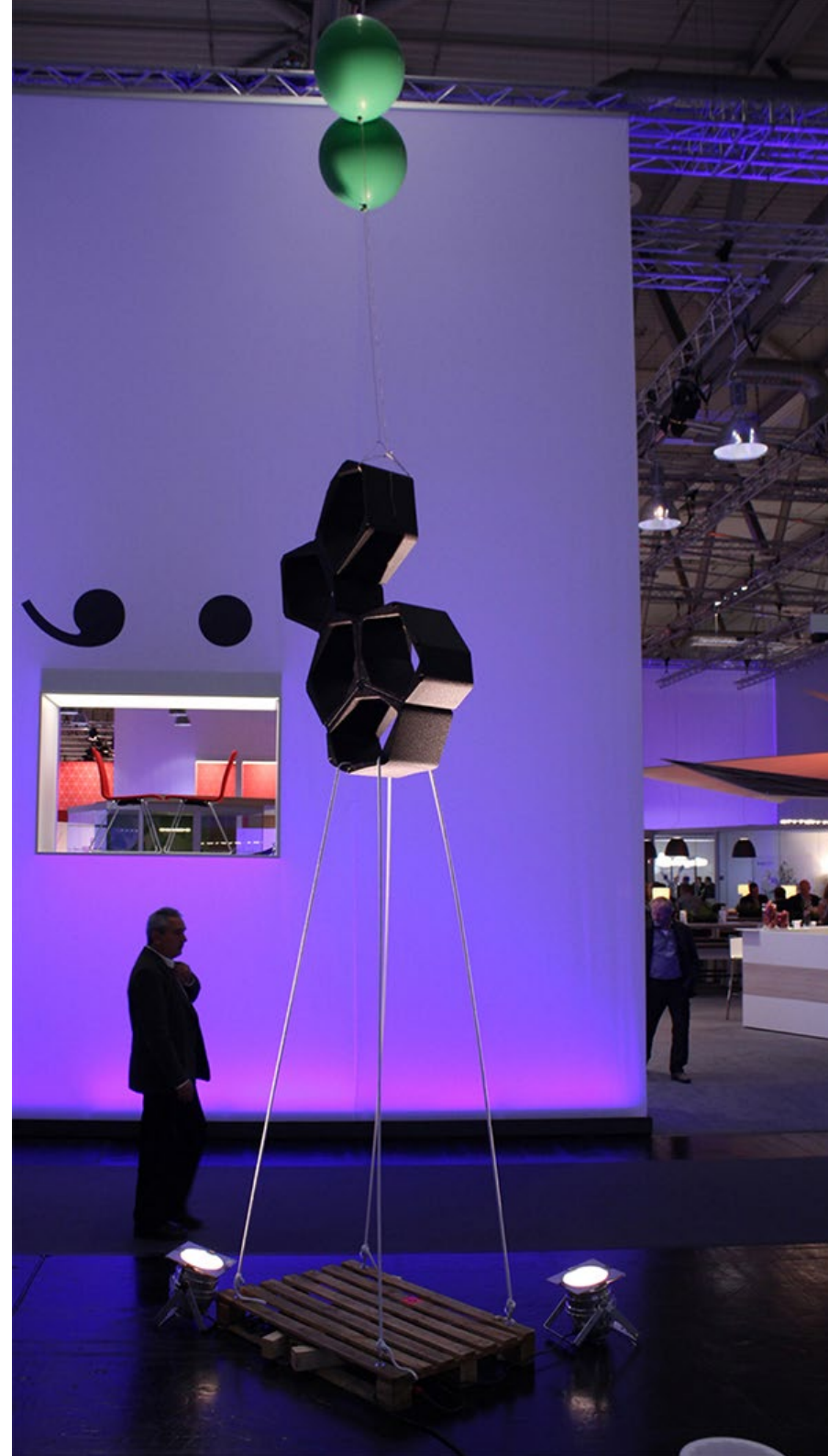

Visit [www.movisi.com](http://www.movisi.com)